

Type P1615 - Adhesive Profile

Typ P1615 - Klebeleiste

Type P1615 - Profilé Adhésif

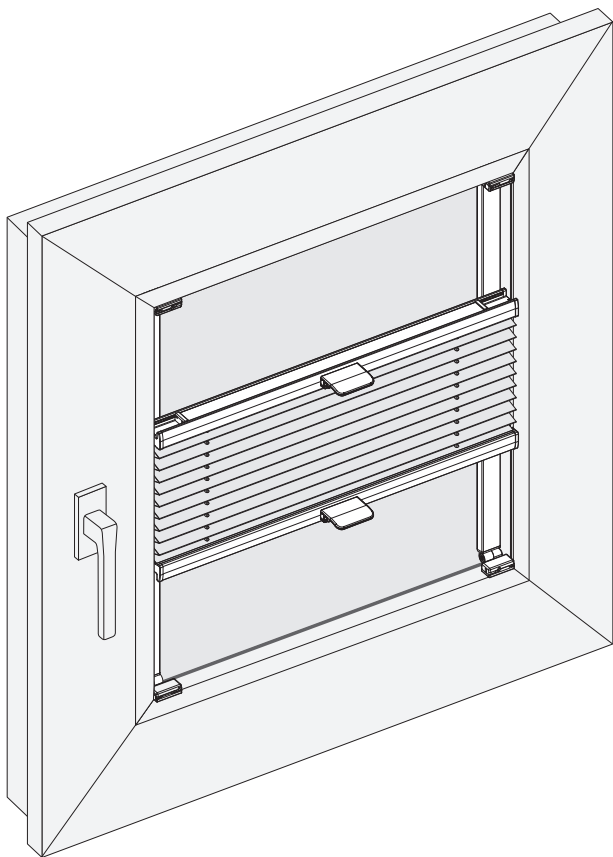

EN Misprints, errors and changes excepted

DE Druckfehler, Irrtümer und Änderungen vorbehalten

FR Sous réserve de fautes d'impression, d'erreurs et de modifications



1 x Torx (TX15)

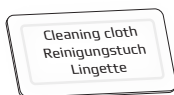

1 x

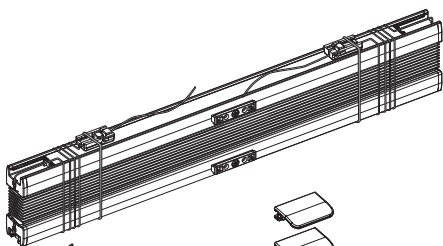

1 x



2 x

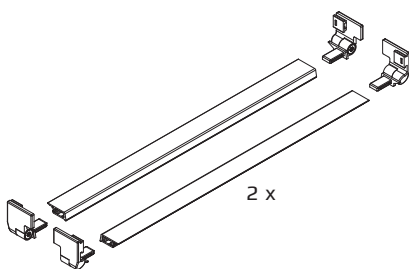

2 x

4 x (2 x l / 2 x r)

1

Cleaning cloth
Reinigungstuch
Lingette

Isopropanol (100%)
Ethanol

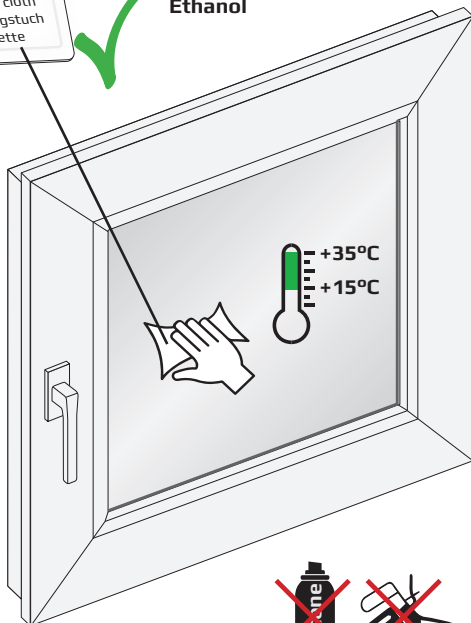

2

Cloth (dry and lint-free)
Tuch (trocken und fuselfrei)
Chiffon (sec et non pelucheux)

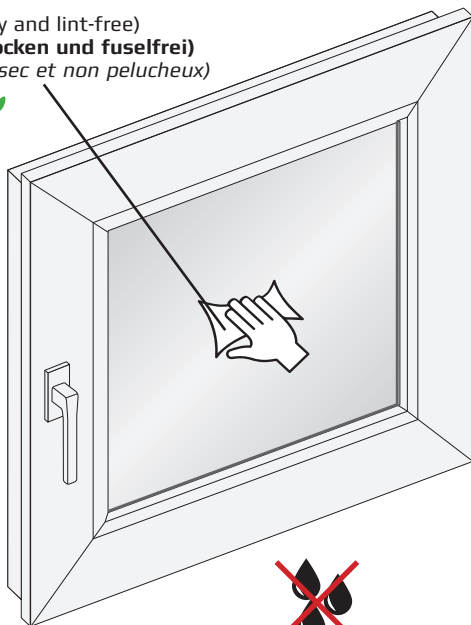

3

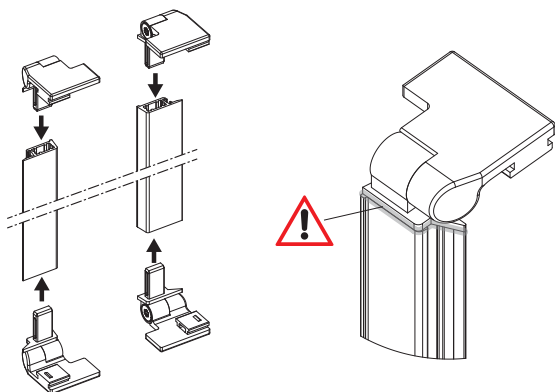

4

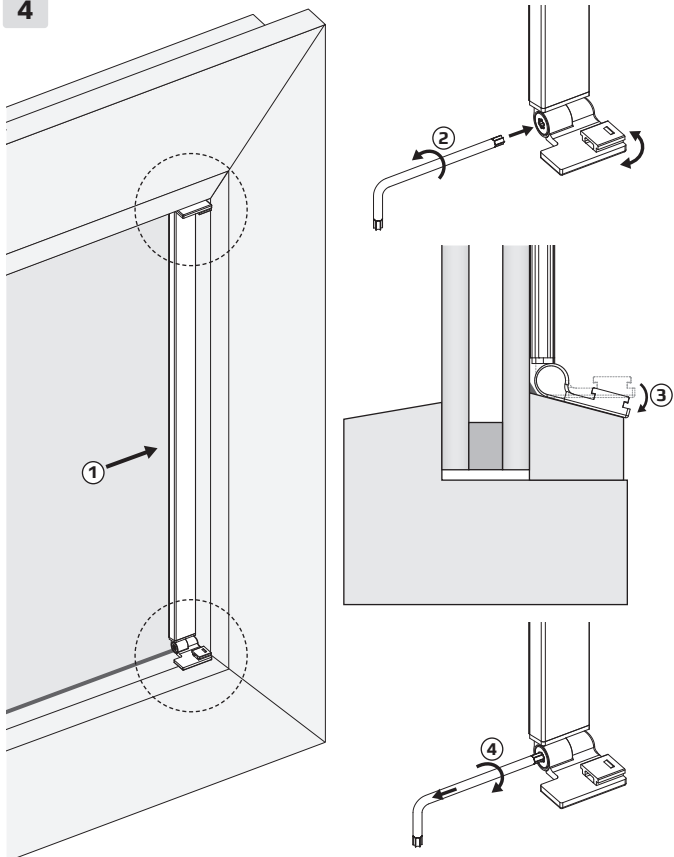

Adhesive tape: tesa® ACXplus 7055

http://www.tesa.com/industry/tesa_acxplus

<https://www.benthin.com/en/blinds/pleated-blinds/>

Klebeband: tesa® ACXplus 7055

http://www.tesa.de/industrie/tesa_acxplus

<https://www.benthin.com/produkte/plissee>

Ruban adhésif : tesa® ACXplus 7055

http://www.tesa.fr/industrie/tesa_acxplus

<https://www.benthin.com/fr/produits/plissee/>

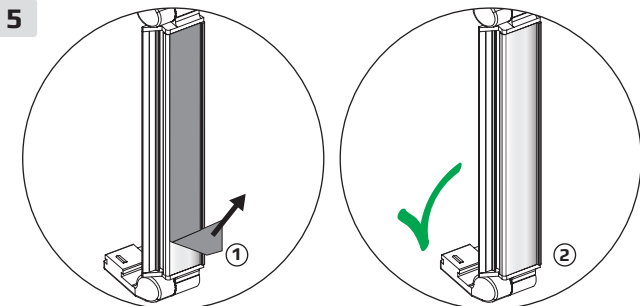

Do not touch the adhesive surfaces!

The adhesive support cannot be repositioned due to the immediate adhesive effect and the adhesive tape cannot be used again!

Klebefläche nicht berühren!

Der Klebeträger kann durch die sofort wirkende Klebewirkung nicht mehr neu positioniert werden und das Klebeband kann nicht erneut verwendet werden!

Ne pas toucher la surface adhésive !

Le support adhésif ne peut pas être repositionné en raison de l'effet adhésif immédiat et le ruban adhésif ne peut pas être réutilisé !

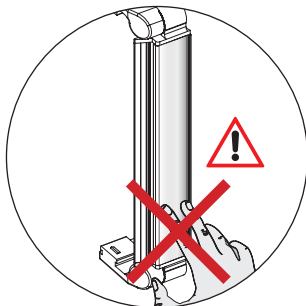



The adhesive profile will immediately adhere to the surface. Therefore, it cannot be repositioned and the adhesive strip cannot be reused!

Wegen der sofort einsetzenden Klebewirkung kann die Klebeleiste nicht mehr neu positioniert werden und das Klebeband kann nicht erneut verwendet werden!

La colle agissant immédiatement, il est impossible de repositionner le profilé adhésif et de réutiliser la bande adhésive !

6

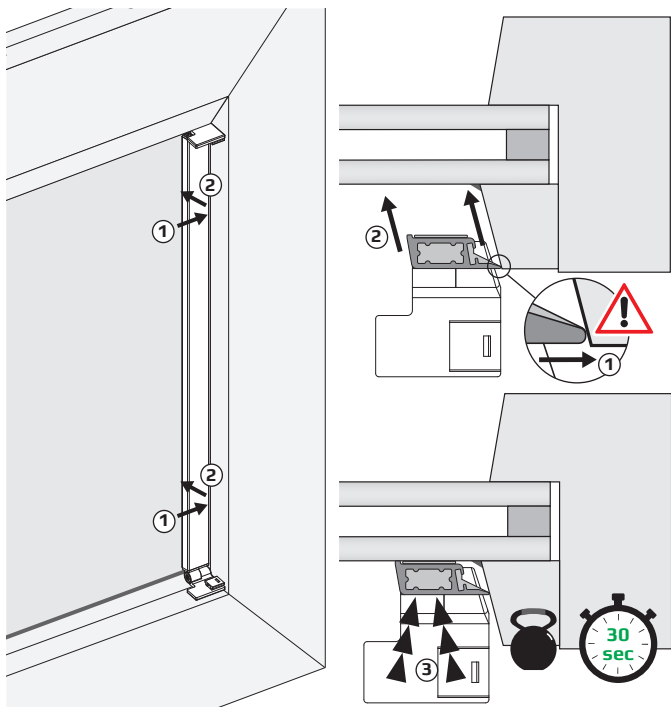

The pressure force is a prerequisite for an optimal connection and prevents the formation of air bubbles.

Die Andruckkraft ist Voraussetzung für eine optimale Verbindung und verhindert die Bildung von Luftblasen.

La force de pression est une condition préalable à un assemblage optimal et empêche la formation de bulles d'air.



Adhesive strength
Klebekraft
Pouvoir adhésif



20 min = 50%
1 h = 75%
24 h = 90%
72 h = 100%

7

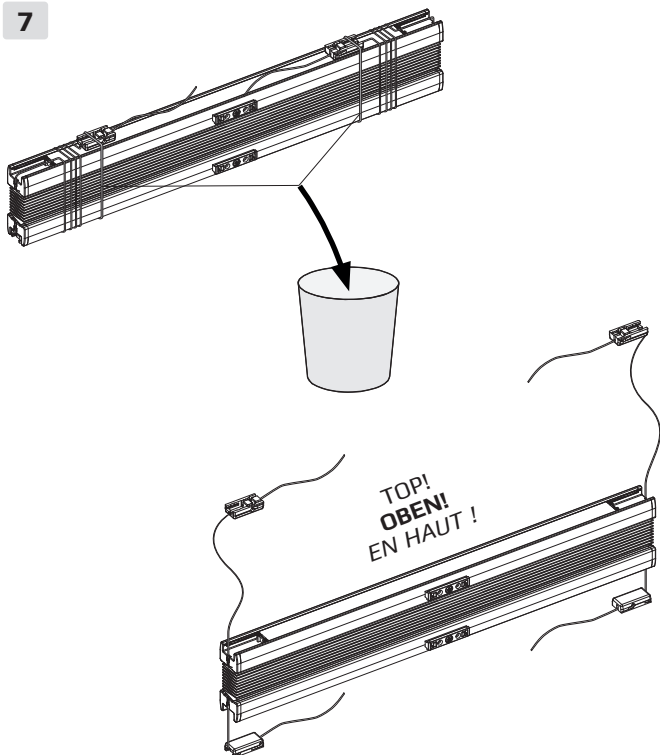

8

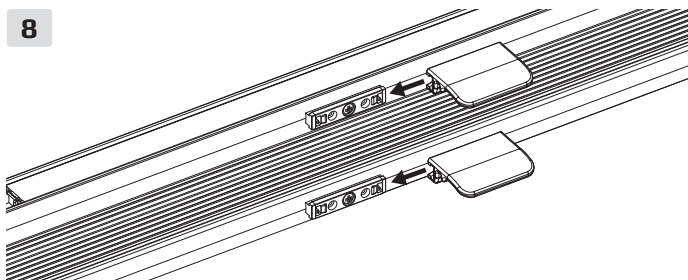

9

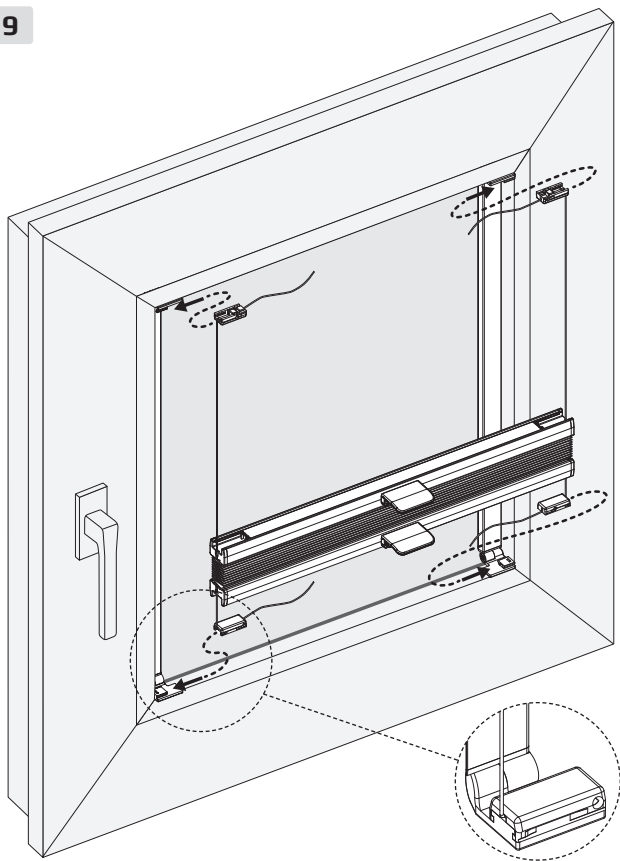



10

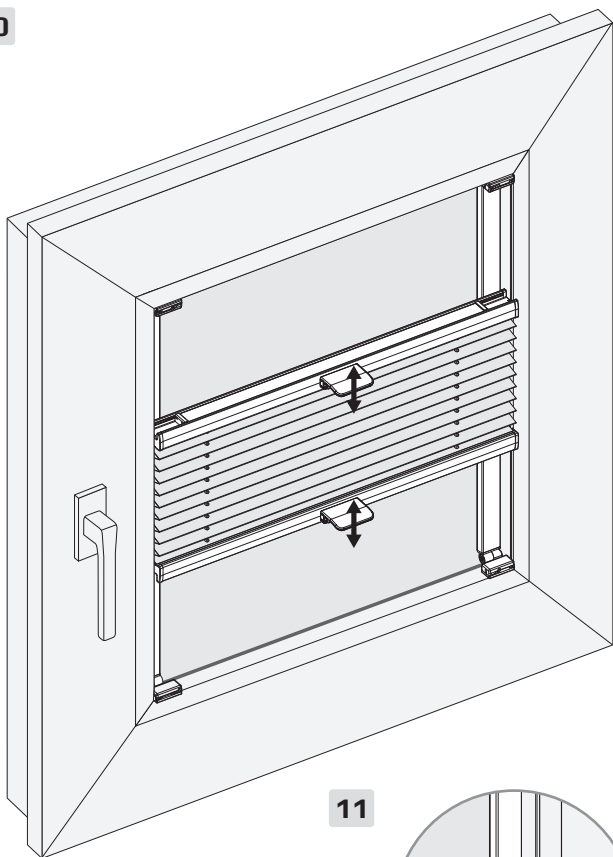

11

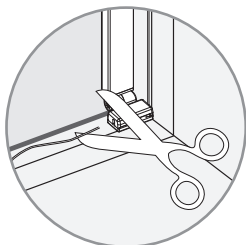

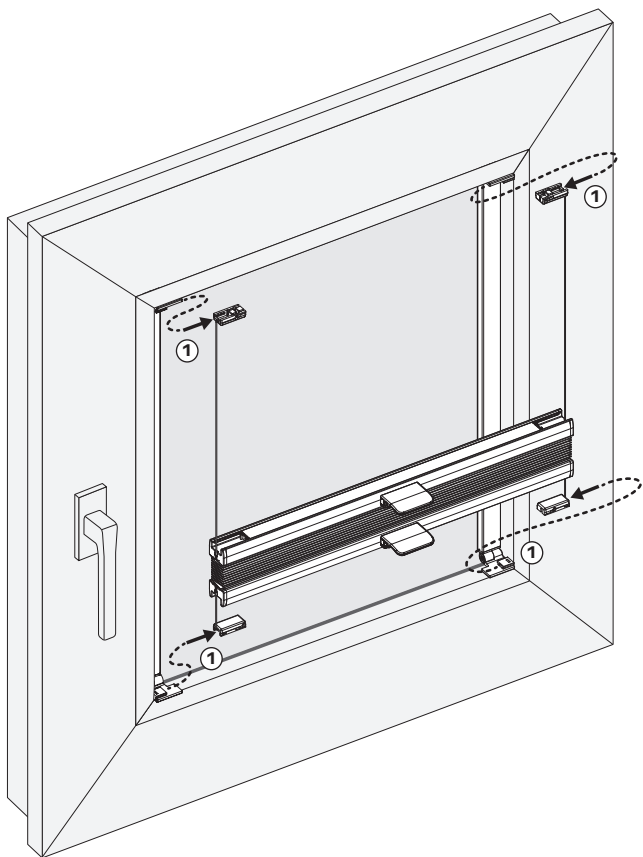

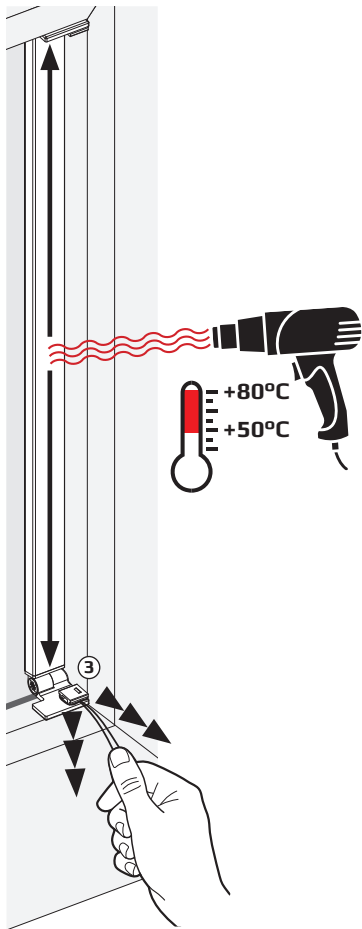
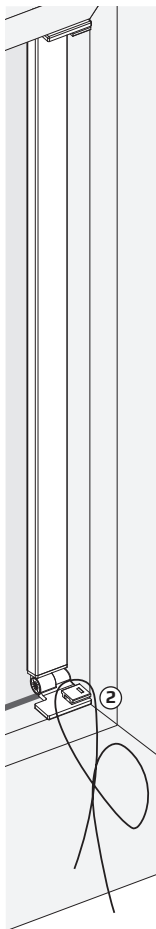

Adhesive remover
Klebstoffentferner
Décolleur de colle

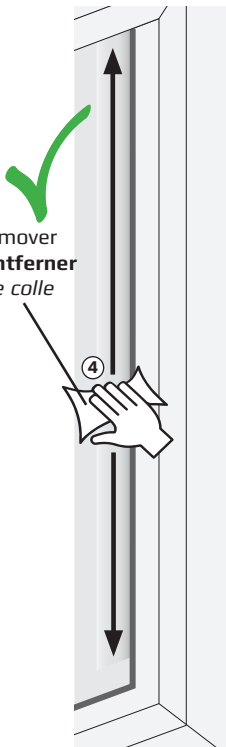

Cloth (dry and lint-free)
Tuch (trocken und fuselfrei)
Chiffon (sec et non pelucheux)

