

# DF16

Roof window Roller Blind  
**Dachflächenrollo**  
*Rouleaux de fenêtre de toit*

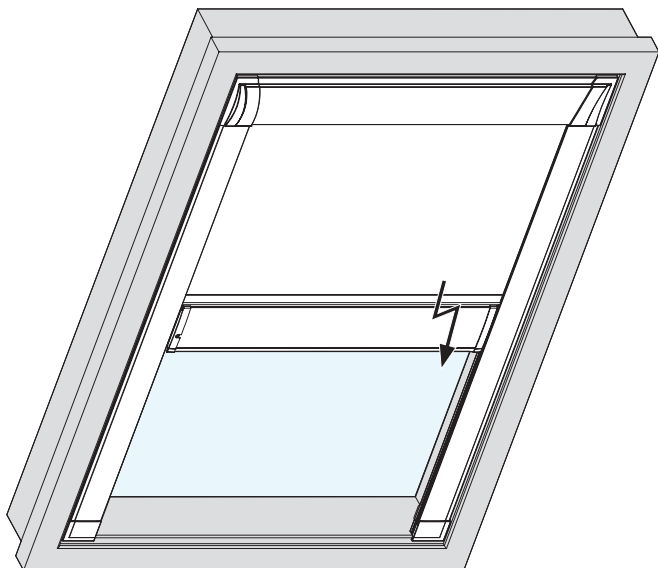

**DF16**

Misprints, errors and changes excepted

**Druckfehler, Irrtümer und Änderungen vorbehalten**

*Sous réserve de fautes d'impression, d'erreurs et de modifications*

# Content . Inhalt . Contenu

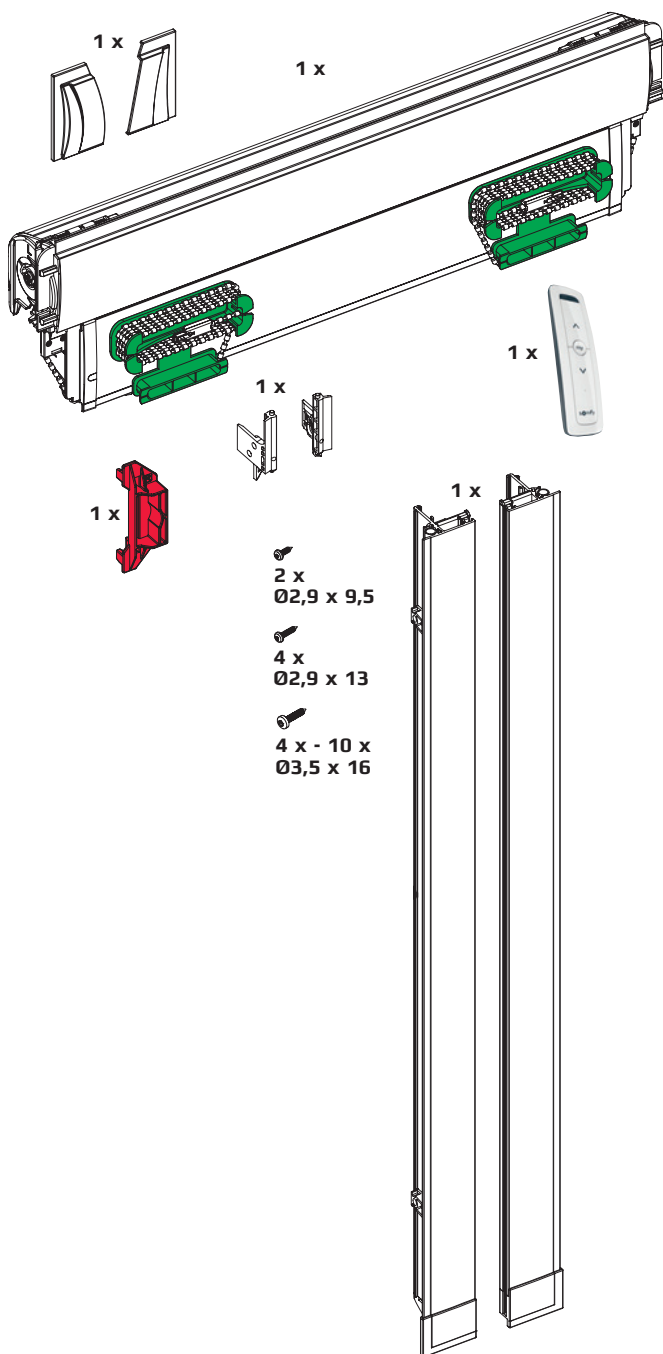

# Installation . Montage . Pose

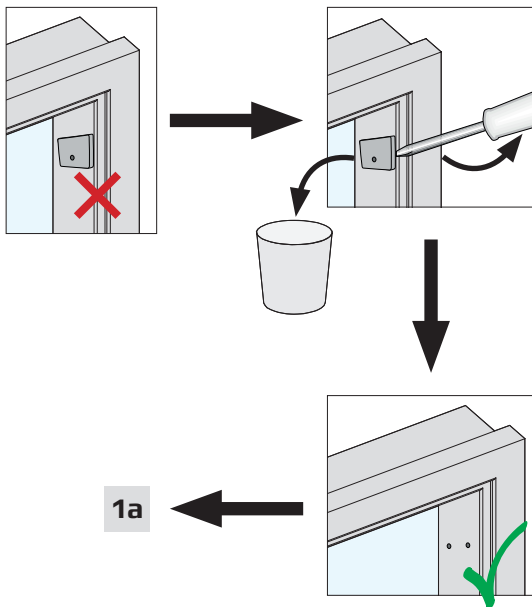
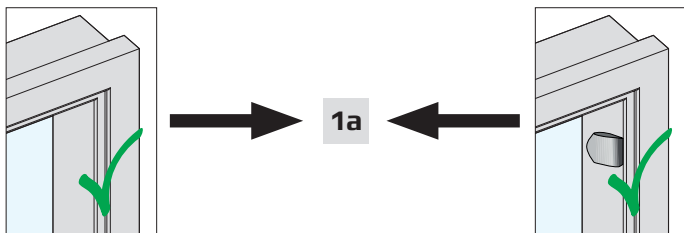

# Installation . Montage . Pose

1a

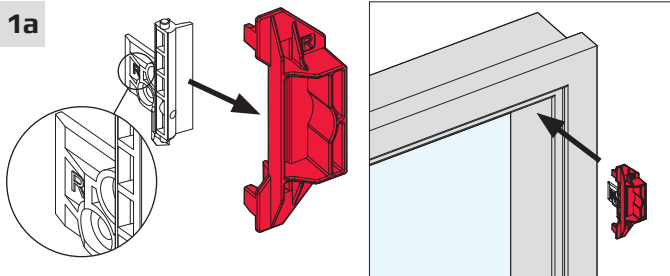

2a

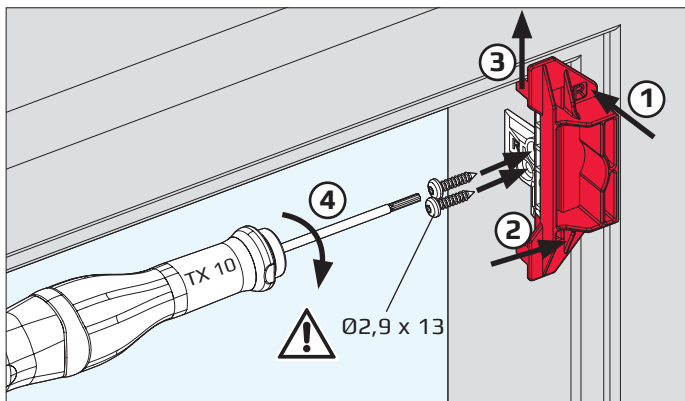

3a

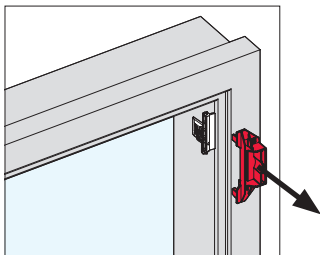

# Installation . Montage . Pose

1b

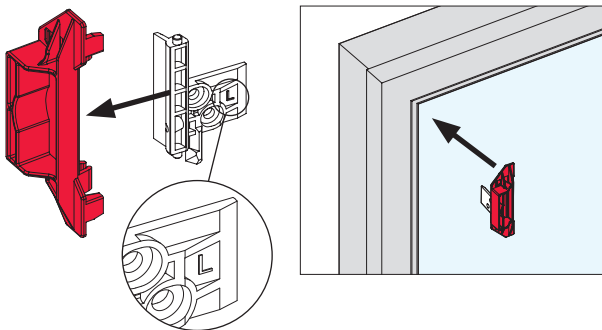

2b

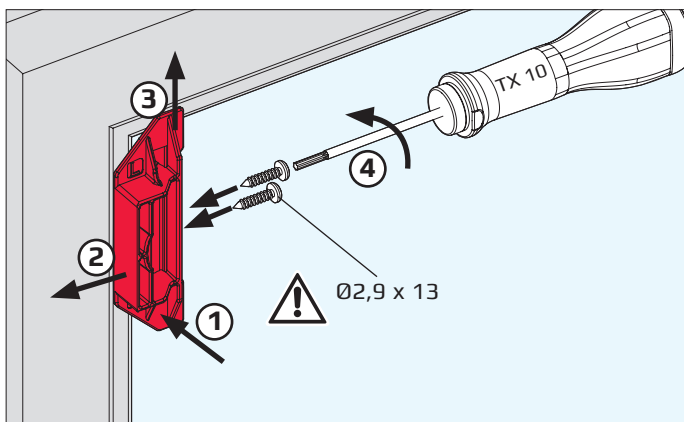

3b



4

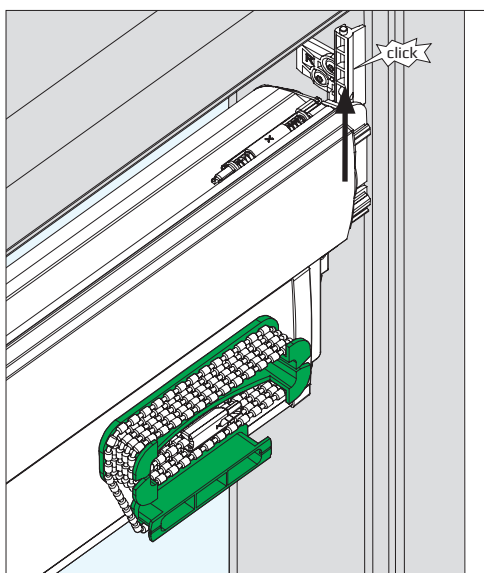
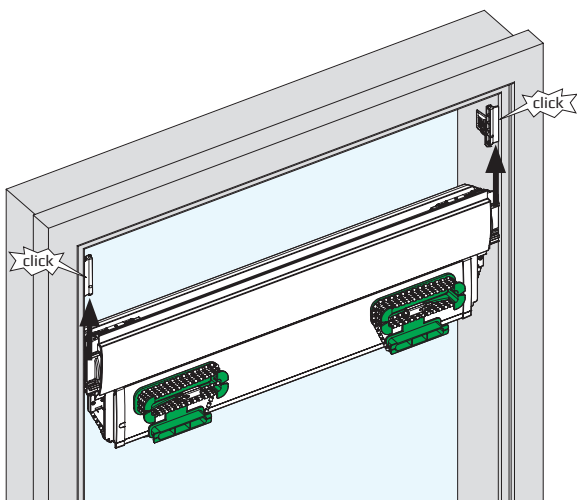

5

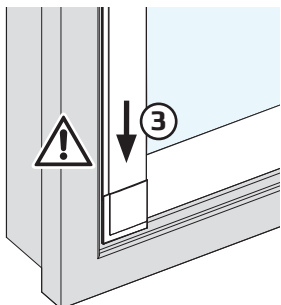
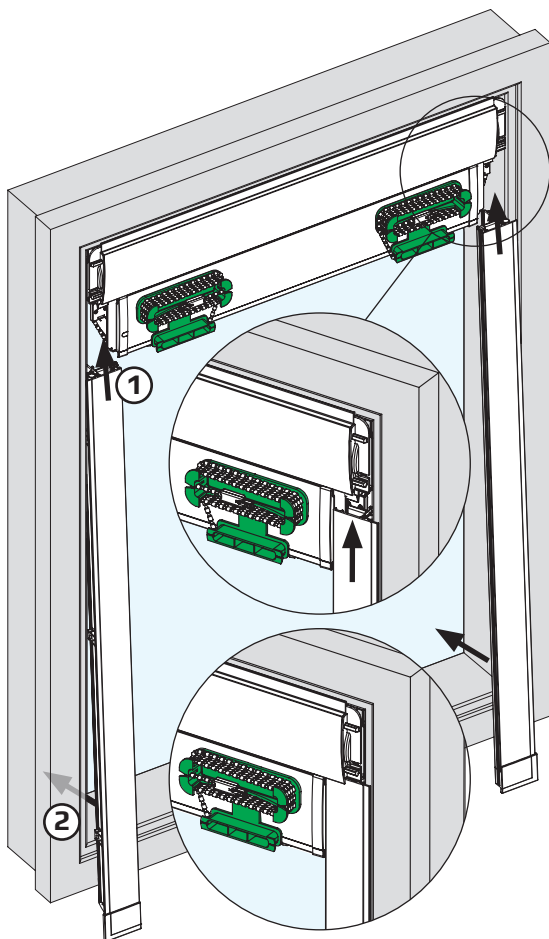

6

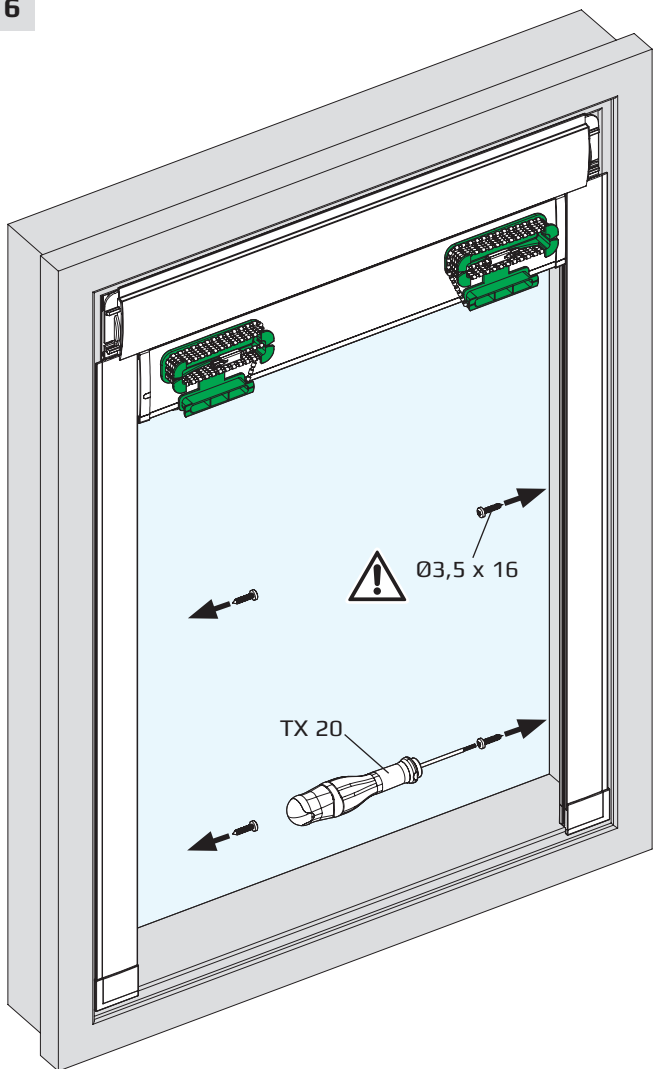



7

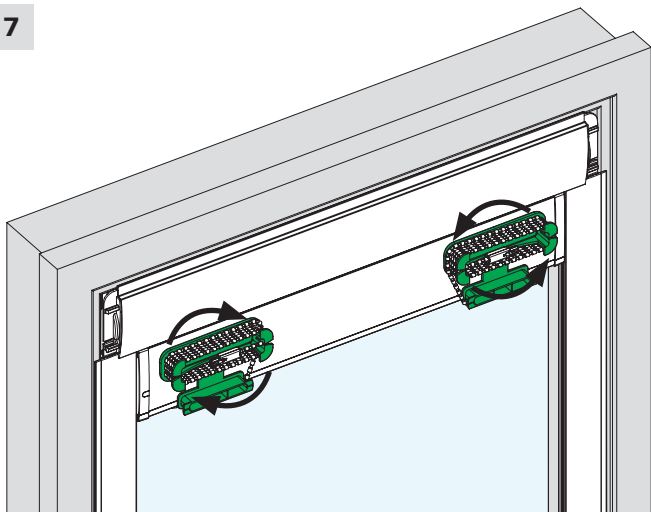

8

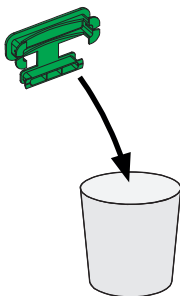
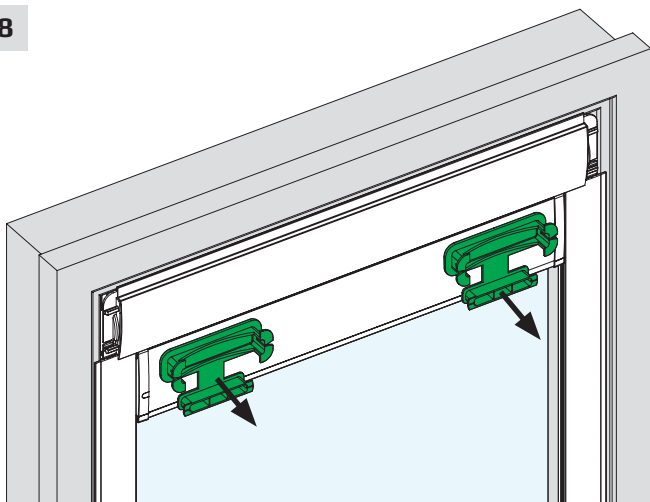

9

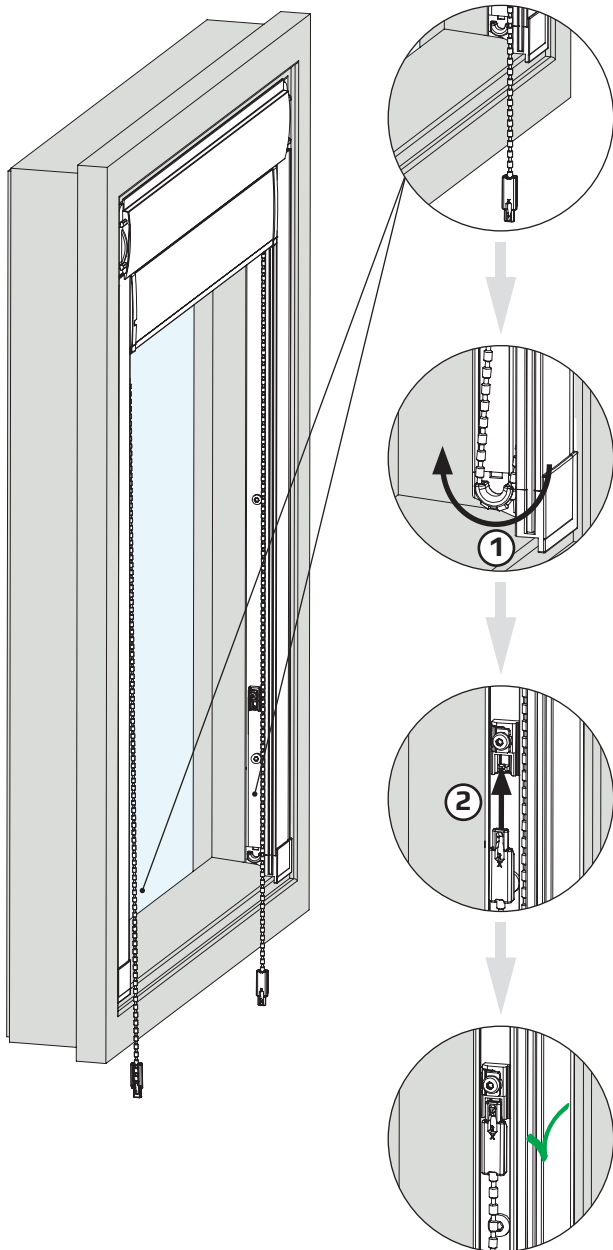

10

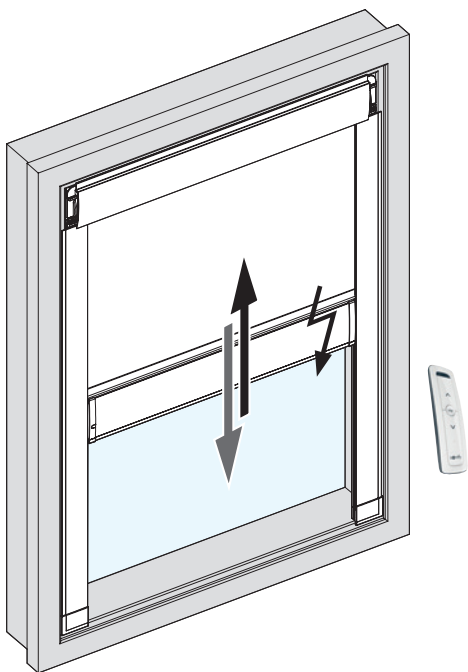
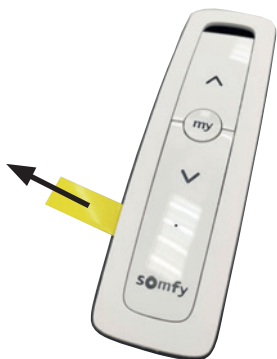

11

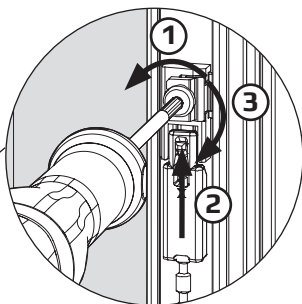
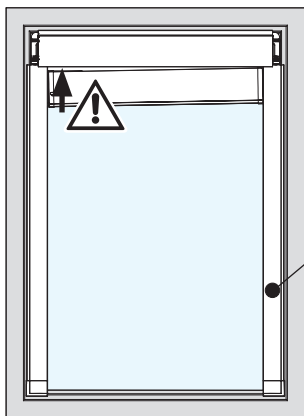
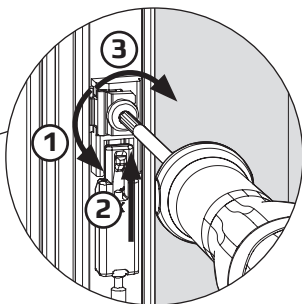
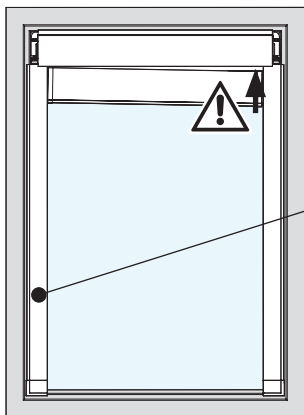
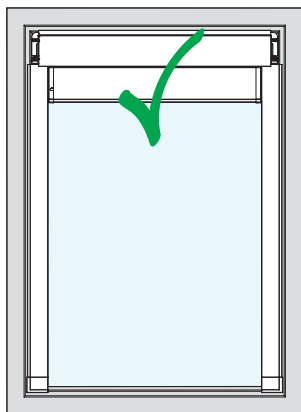
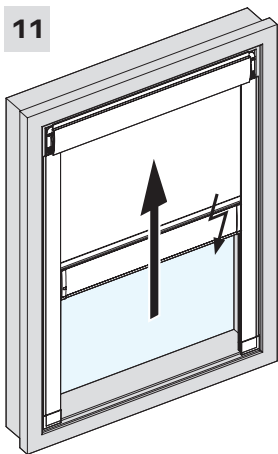

12

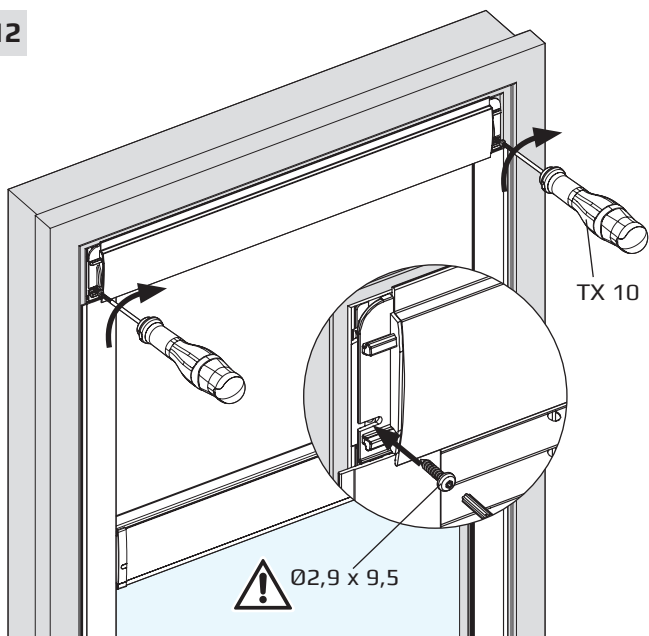

13

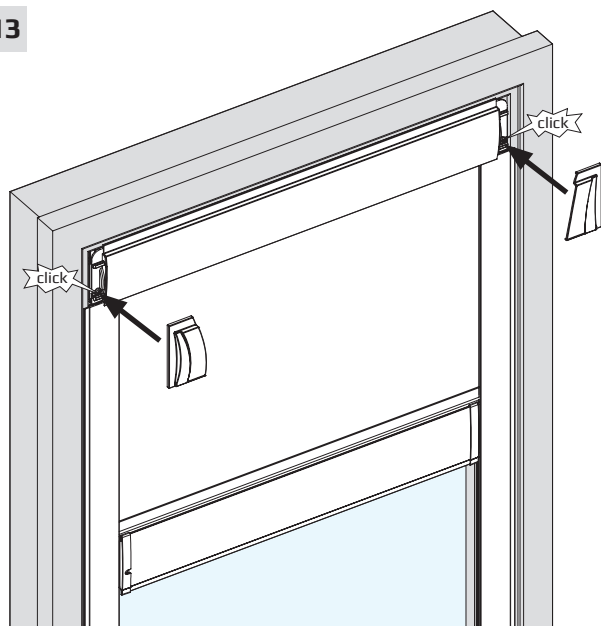

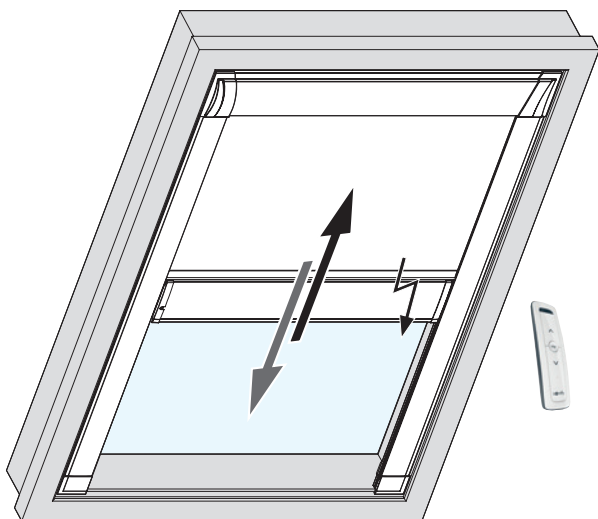

All functions of the remote control can be found in the SOMFY operating instructions or under:

**Alle Funktionen der Fernbedienung sind in den Gebrauchsanweisung von SOMFY einsehbar oder unter:**

*Toutes les fonctions de la télécommande sont disponibles dans le mode d'emploi de SOMFY ou sur le site :*

<https://downloads.somfy.de/frontend/getcatalog.do?catalogId=174470&catalogVersion=1&lang=de>

# Battery charge . Akku laden . Charge de la batterie

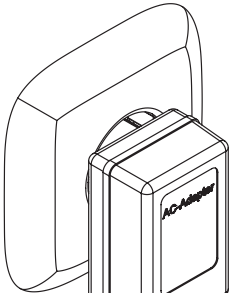
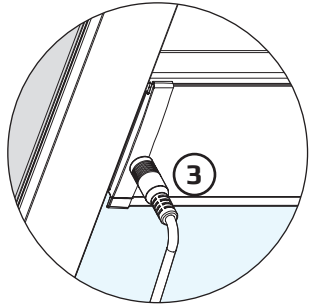
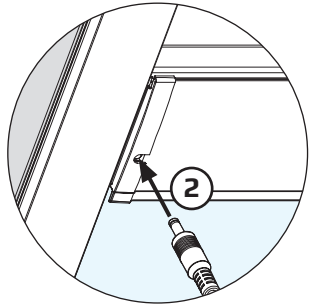
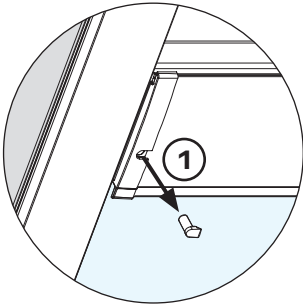

The battery is charging  
**Der Akku wird geladen**  
*La batterie est en charge*



fully charged  
**vollständig geladen**  
*complètement chargé*

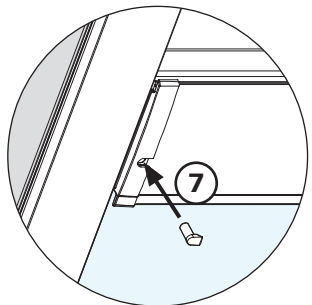
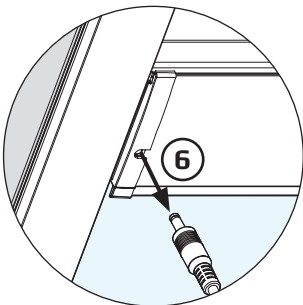

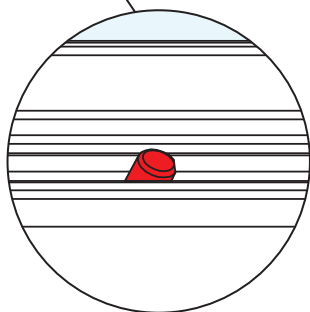
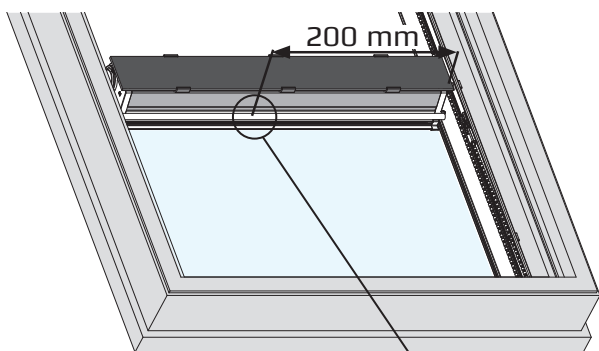
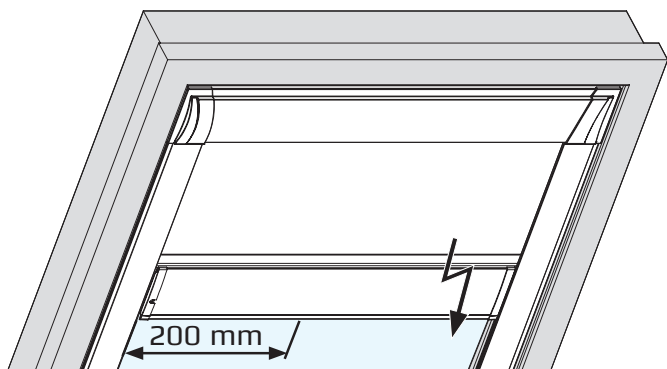

For further settings and functions of the SOMFY Tilt & Lift 25 RTS, see SOMFY instructions or visit SOMFY.de

**Weitere Einstellungen und Funktionen des SOMFY Tilt & Lift 25 RTS siehe SOMFY-Anleitungen oder unter SOMFY.de**

*Pour d'autres réglages et fonctions du SOMFY Tilt & Lift 25 RTS, voir les instructions SOMFY ou sur SOMFY.de*



# Information

Power supply:

Battery pack NiMH (nickel-metal hybrid) 12 V / 1800 mAh / 21.6 Wh

Charger 12 V DC / 0.5 A

Solar panel (monocrystalline silicon) 12 V DC / 121 mA

**Stromversorgung:**

**Akkupack NiMH (Nickel-Metallhydrid) 12 V / 1800 mAh / 21,6 Wh**

**Ladegerät 12 V DC / 0,5 A**

**Solarpanel (monokristallines Silizium) 12 V DC / 121 mA**

*Alimentation électrique :*

*Pack batterie NiMH (nickel-métal hybride) 12 V / 1800 mAh / 21,6 Wh*

*Chargeur 12 V DC / 0,5 A*

*Panneau solaire (silicium monocristallin) 12 V DC / 121 mA*

Environmental note/disposal

This product is labelled in accordance with the European Directive 2012/19/EU on waste electrical and electronic equipment (WEEE). - WEEE).

This directive provides the framework for the EU-wide EU-wide take-back and use of waste equipment.

Note on disposal

We want to protect the environment!

At the end of its service life, the built-in rechargeable battery must not be disposed of with normal household waste. Dispose of the battery in accordance the applicable regulations at a specialist shop or at an to an authorised recycling centre.



**Umwelthinweis/Entsorgung**

**Dieses Produkt ist entsprechend der europäischen Richtlinie 2012/19/EU über Elektro- und Elektronikaltgeräte (waste electrical and electronic Equipment - WEEE) gekennzeichnet.**

**Die Richtlinie gibt den Rahmen für eine EU-weit gültige Rücknahme und Verwendung der Altgeräte vor.**

**Hinweis zur Entsorgung**

**Wir wollen die Umwelt schützen!**

**Der eingebaute aufladbare Akku darf am Ende seiner Lebensdauer nicht über den normalen Hausmüll entsorgt werden. Geben sie den Akku entsprechen den geltenden Vorschriften im Fachhandel oder bei einer zugelassenen Recycling-Sammelstelle ab.**



*Avis environnemental/Élimination*

*Ce produit est étiqueté conformément à la directive européenne 2012/19/UE relative aux déchets d'équipements électriques et électroniques (DEEE).*

*La directive fournit le cadre pour la reprise et l'utilisation des équipements usagés à l'échelle de l'UE.*

*Note sur la cession*

*Nous voulons protéger l'environnement !*

*La batterie rechargeable intégrée ne doit pas être jetée avec les déchets ménagers normaux à la fin de sa durée de vie. Mettez la batterie rechargeable au rebut conformément à la réglementation en vigueur dans un magasin spécialisé ou dans un point de collecte de recyclage autorisé.*



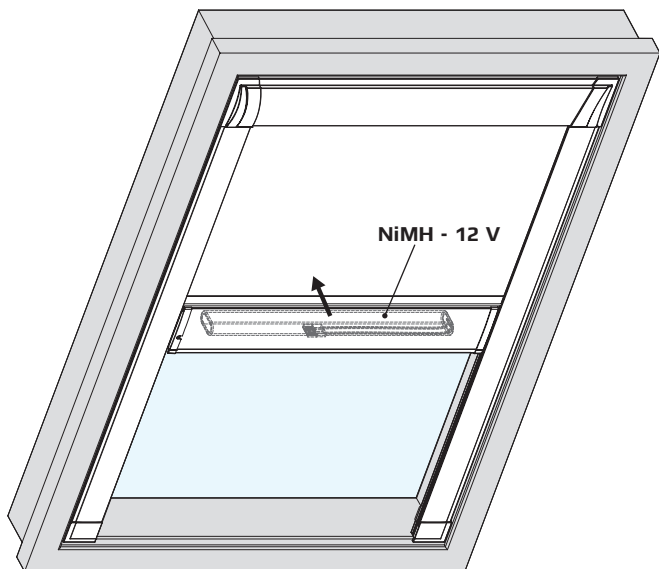

1

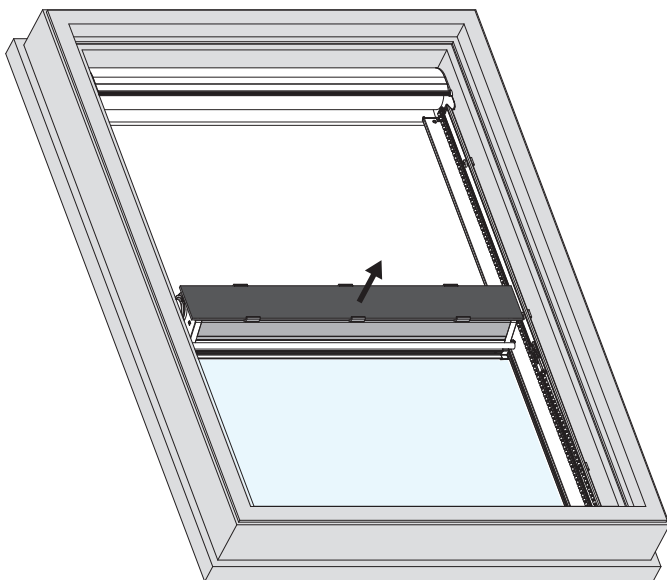

2

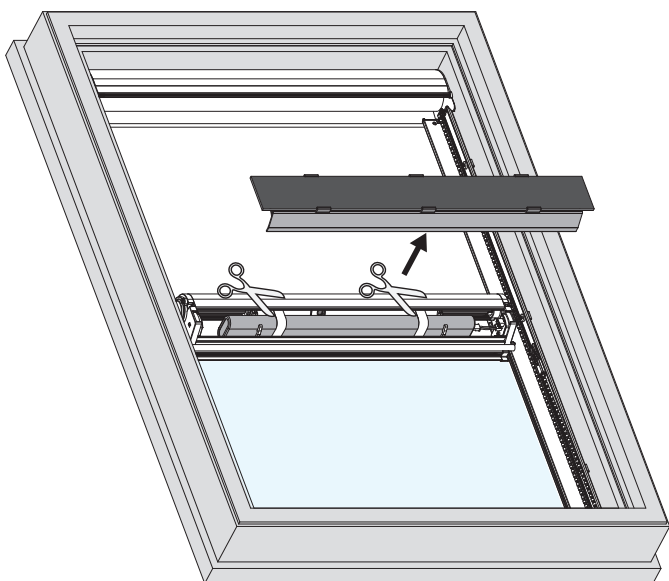

3

